

# Lead-Acid Battery Desulfator



Homebrew

Alastair Couper

©2000 Alastair Couper

It was twenty years ago that I left my on-grid home, and my job as an electronics engineer, to begin life on an alternative energy oriented organic farm. In the intervening years, I have installed, maintained, and experimented with numerous RE systems in my area. What I have come to understand from this experience is that off-grid life tends to become very much focused on the battery bank and its fate.

All power sources and loads breathe through this crucial pathway. Batteries are heavy, toxic, inefficient, and—to the amazement of many—electrically very fragile. Weak or failing batteries are a very likely cause of breakdown, especially in smaller solar-electric systems.

Most newcomers to renewable energy are quite familiar with using water tanks or gas tanks, and naturally use this familiarity in trying to understand their battery banks. Everyone knows that a bigger water tank is better than a small one. Unfortunately, batteries are not like tanks, and the result is trouble.

It is definitely not true that a big battery bank is necessarily better than a small one. An oversized battery bank can be almost impossible to charge properly. Without a minimum daily exercise regimen, it can become the equivalent of a couch potato. The main culprit is sulfation, which is a gradual crystallization of the battery's plate material, rendering it electrically inactive.

## Some Theory

Past issues of *Home Power* (see Access) have gone into the details of keeping lead-acid batteries healthy, so I will only touch on the main points here. The usual practice in maintaining a battery in good condition is to apply a periodic equalization charge over and above what would be a normal full charge. Unfortunately, this

is an energy-wasting tactic. It ultimately results in clean battery plates, but at a steep price, especially if the energy must come from a generator.

I initially went to the Internet to find any available information on the problem of sulfation. The search engines turned up several commercial sites that give useful details on the fine points of battery charging and equalization. A second resource is the IBM patent server ([www.patents.ibm.com](http://www.patents.ibm.com)). I found relevant patents there, using keywords like “desulfate” and “rejuvenate.”

What this wealth of data shows is that there are numerous strategies for charging and electrically desulfating batteries. Most of them were designed or developed in the last twenty years or so. Considering that lead-acid batteries have been around for more than a century, this is a relatively new innovation. Virtually all of the devices and patents I found have in common the use of some form of pulsing charge current. This is in contrast to the constant or slowly varying currents generated by sources like solar-electric panels.

I distilled and simplified these various techniques, and came up with a basic circuit that will keep small to medium sized batteries in desulfated condition. It can even be used to bring old, sulfated units back into service. Use of the circuit has dramatically reduced the need for equalization charges in my own home system.

## Resonant Frequency

The technique used in this circuit relies on a little known aspect of lead-acid batteries. They possess what is called a “resonant frequency,” at a surprisingly high frequency. The frequency is dependent on various physical details of the battery's construction, but it is on the order of 2 to 6 megahertz, which is in the low ranges of the shortwave radio bands.

Figure 1: 12 Volt Battery Desulfator

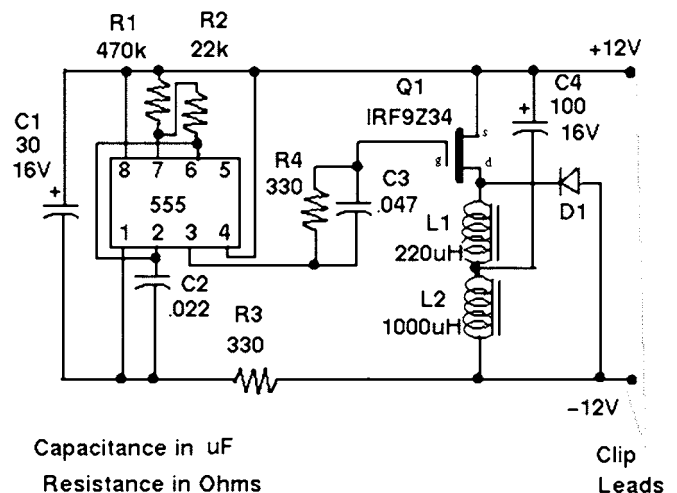
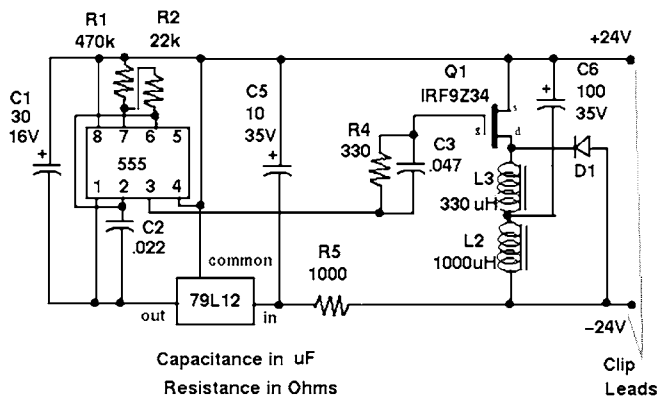

Figure 2: 24 Volt Battery Desulfator



This resonance is just like that of a stringed musical instrument, where a pluck of the string creates a vibration of a specific tone. In the case of the battery, sulfur ions dissolved in the electrolyte take the place of the string. A sufficiently energetic electrical “pluck,” or pulse, will cause a similar vibration of these ions, back and forth throughout the electrolyte.

When this vibrational state is occurring, there are uncountable collisions between the ions in the electrolyte and the battery plates, as the back and forth vibration continues. It is this rhythmic beating of the plates which causes the breakup of the crystalline deposits, slowly but surely, for as long as the electrical pulsations are applied.

It is not unlike sandblasting a rough surface, but on a micro-physical level. This is an advantage of electrical methods over the use of chemicals like EDTA. Rather than dissolving the sulfate deposit and allowing it to settle on the bottom of each cell, as with EDTA, the pulse technique returns the sulfate back into solution again.

#### Circuit Details

The circuit is in essence a very widely used form of switching DC-to-DC convertor, which can take a DC voltage and step it up to a higher level. Figure 1 shows the version which is specifically for 12 volt systems. The basic pulse rate is set by the venerable 555 timer chip, U1, which switches the MOSFET Q1 at a 1 kHz rate.

When Q1 is in the non-conducting state, current is drawn from the battery through L2 so that capacitor C4 can be charged slowly. Then Q1 is turned on for a brief 50 microseconds, causing the charge stored in C4 to start flowing through L1.

When Q1 is turned off again, the stored inductive energy in L1 has to continue to flow somewhere, so it pulses back into the battery through diode D1. This current pulse can get as high as 6 amps. The use of an inductor to supply this pulse is what makes it possible to restore badly sulfated batteries with a high internal resistance. The peak voltage drop across the battery can initially be as high as 50 volts. With continued treatment, this peak voltage will decrease as the battery's internal resistance gradually declines.

Figure 2 shows the version for use in 24 volt systems. Its only additional feature is the use of a 79L12 voltage regulator (component U2, Digi-Key part number NJM79L12A-nd) to convert the 555's input voltage down to 12 volts. Also L3 (Digi-Key part number DN4518-nd) is increased in value over L1 in the 12 volt unit, to compensate for the higher terminal voltage.

#### Lead-Acid Battery Desulfator Parts List

Item	Component	Description	Cost (US\$)
Q1	IRF9Z34	P channel MOSFET	1.82
U1	LM555CN	Timer IC	0.42
U2**	79L12	12 V regulator	0.36
D1	GI826CT	Fast recovery diode, >6 A, 100 V	0.77
C1	30 $\mu$ F, 16 V	Electrolytic	0.23
C2	0.022 $\mu$ F	Disk ceramic	0.38
C3	0.047 $\mu$ F	Disk ceramic	0.54
C4*	100 $\mu$ F, 16 V	Electrolytic, low impedance type	0.44
C5**	10 $\mu$ F, 35 V	Electrolytic	0.23
C6**	100 $\mu$ F, 35 V	Electrolytic	0.49
R1	470 k $\Omega$	1/4 W	0.15
R2	22 k $\Omega$	1/4 W	0.15
R3*	330 $\Omega$	1/4 W	0.15
R4	330 $\Omega$	1/4 W	0.15
R5**	1 k $\Omega$	1/4 W	0.15
L1*	220 $\mu$ H (nominal)	Ferrite inductor, 6+ A peak	2.08
L2	1000 $\mu$ H	Ferrite choke, 100 mA	3.12
L3**	330 $\mu$ H	Ferrite inductor, 6+ A peak	2.08
	Case	Aluminum project box	5.44
	Clip leads	Alligator type, insulated (RS)	1.00
	Board material	0.1" spaced copper pads	3.00

Total for 12 V Unit \$19.84

\* For 12 V unit only.

\*\* For 24 V unit only.

Total for 24 V Unit \$20.48

If an oscilloscope is available, it is easy to observe the ringing wave form across the battery terminals. It is likely that more than one frequency will be apparent, due to all the wiring and other details of the setup. It should be possible to see a small spark jump from the leads of the pulse generator as it is connected, a result of the high peak voltage available (keep this in mind if your batteries are not well ventilated). Depending on the case, and the type of inductors used for L1 and L2, a faint audio tone can also be heard when the circuit is operating. Digi-Key part number DN4516-nd will work for L1, and DN7437-nd will work for L2.

There is no reverse polarity protection in this circuit, so make sure that the leads are clearly marked. A mistake will result in damaged components. Also, it is not a good idea to expose the 12 volt circuit to more than 16 volts at the terminals.

See the parts table for a detailed component list. But don't get too attached to using exactly these components, or to buying new stuff. The homebrew ethic is based on an ability to make do, come up with alternatives, and recycle. My first trial units had quite a bit that was clipped out of old junk circuit boards.

### Usage

It should be emphasized that pulsing energy to and from the battery happens at less than 100 percent efficiency. This circuit draws about 40 mA from the battery while in operation (less than 1 amp-hour per day), so some additional charging source is needed. For reconditioning a sulfated battery, I simply clip the circuit across the battery terminals in parallel with a 30 watt solar panel.

In my initial testing, it took a month to partially reclaim a pair of golf cart batteries that had been allowed to sit, discharged, for almost a year. They had such a high internal resistance that a very small current would take the terminal voltage over 16 volts.

For use in a functioning power system, you can clip the circuit across the main battery terminals, using as short a lead length as possible. When external equipment, such as an inverter, is connected across a battery bank, then additional low impedance paths are formed. The desulfator's current pulses will happily flow down these paths as well, and it serves no purpose for the pulses to flow into the inverter.

I had initially thought that this shunting, or dilution, of the current pulses away from the battery would be a problem. This has not proven to be the case, however, because the impedance of typical inverters at frequencies above 1 megahertz is not very low. (Note: impedance is just a fancy word for resistance, taking

into account the circuit's behavior at different frequencies.)

One way to keep the external equipment from shunting away the current pulse would be to take some ferrite toroid cores and slip them over the battery leads as they leave the bank. This will increase the high frequency impedance without affecting the DC performance of the circuitry.

The circuit as shown, with its approximately 6 amp peak capacity, is probably strong enough to maintain a bank of several hundred amp-hours. If you want to use the circuit with larger banks, it will be necessary to select D1, L1, and L2 for higher current capacity. You will also need to vary the pulse width from the 555 accordingly, so that Q1 is allowed to stay on for a longer period of each cycle. If you want to power the circuit from an auxiliary voltage source, so that the battery being treated remains trickle charged, simply remove R3 and place 12 volts across C1.

It's best to construct the unit in a shielded case. Otherwise it is likely to generate a fair bit of radio interference. The use of the shortest possible lead length is also a good idea. All the components are available from any general electronics distributor. Radio Shack is as good a place as any for getting the case, clip leads, circuit board, and other components.

### Does It Work?

If badly sulfated batteries are treated, it is convenient to use a trickle charger of one or two amps. In this case, the simplest way to see that the circuit is having an effect is to note that the terminal voltage actually *drops* each day as the batteries slowly charge. This is a result of the internal resistance of the cells decreasing as the plates become slowly cleared of the sulfate, and more useful plate area comes in contact with the electrolyte. Also, the specific gravity of the cells begins to rise slowly, evidence that the sulfate is going back into solution.

To further check the progress, you could do a discharge test, using a known load, to determine the useful capacity. This would involve measuring the length of time taken by the load to drop the battery voltage from a high level to a low level. If you repeat this test, a gradual lengthening of this interval should be noted.

In one system I worked with, at first the batteries would not power even a small load. After treatment, they were able to run loads in the neighborhood of 5–10 amps for a few hours. This is far from "like new" condition, but it was sufficient for them to be returned to use in the small PV system they were taken from. I expect that further treatment would have helped. It seems that the process

is inherently slow. Lead sulfate is just not very willing to return into solution.

### Healthy Batteries

I have used this circuit in my main system for over a year, and have not seen the need to equalize in that time (I do not own a generator). All of the cells' electrolyte levels remain in step with each other, and there has been no problem with starting big loads—a sure sign of battery health. Patience is required in reclaiming weak and tired batteries, and no amount of desulfating will help a battery with a shorted cell, or one that has lost plate material through excessive use.

The device is especially useful for automotive batteries that sit for long periods. If you use a generator for equalization, this technique is a must. When you live off-grid, silence is golden.

### Access

Author: Alastair Couper, Kaupo, Maui, HI 96713  
kalepa@shaka.com

### Suppliers:

Digi-Key, PO Box 677, Thief River Falls,  
MN 56701-0677 • 800-DIGIKEY or 218-681-6674

Fax: 218-681-3380 • sales@digkey.com  
www.digkey.com

Mouser Electronics, 11433 Woodside Ave., Santee, CA  
92071 • 800-346-6873 or 619-449-2300  
Fax: 619-562-8796 • sales@mouser.com  
www.mouser.com

Radio Shack, 100 Throckmorton St., Fort Worth, TX  
96102 • 800-843-7422 • 817-415-3011  
Fax: 817-415-3240 • support@tandy.com  
www.radioshack.com

### Web sites of interest:

www.batterybes.com • www.innovativeenergy.com

### Home Power articles:

*Batteries: How to Keep Them Alive for Years and Years...*, by Windy Dankoff, *HP69*, page 46.

*Batteries: What We Know About Them; How to Use Them*, by John Wiles, *HP58*, page 66.

*Preliminary Notes from the EDTA Trenches*, by Stan Krute, *HP 21*, page 36.

*New Life for Sulphated Lead-Acid Cells*, by Richard Perez, *HP20*, page 23.

